Subject: CALIFA-SiTracker-GLAD geometry conflict
Posted by [Anna Corsi](#) on Wed, 08 Mar 2017 15:26:54 GMT
[View Forum Message](#) <> [Reply to Message](#)

Hello,

I find a conflict of geometry among the following detectors, as in attached picture.

```
detGeo.Add(new TObjString("GLAD"),      new TObjString("glad_v13b.geo.root"));
detGeo.Add(new TObjString("CALIFA"),    new
TObjString("califa_17_v8.11_cc0.2.geo.root"));
detGeo.Add(new TObjString("STaRTrack"), new
TObjString("startra_v16-300_2layers.geo.root"));
```

Could you tell me which detectors should be moved to simulate experiments with setup expected for 2018?

Thanks in advance.

Best regards,
Anna

File Attachments

1) 
downloaded 314 times

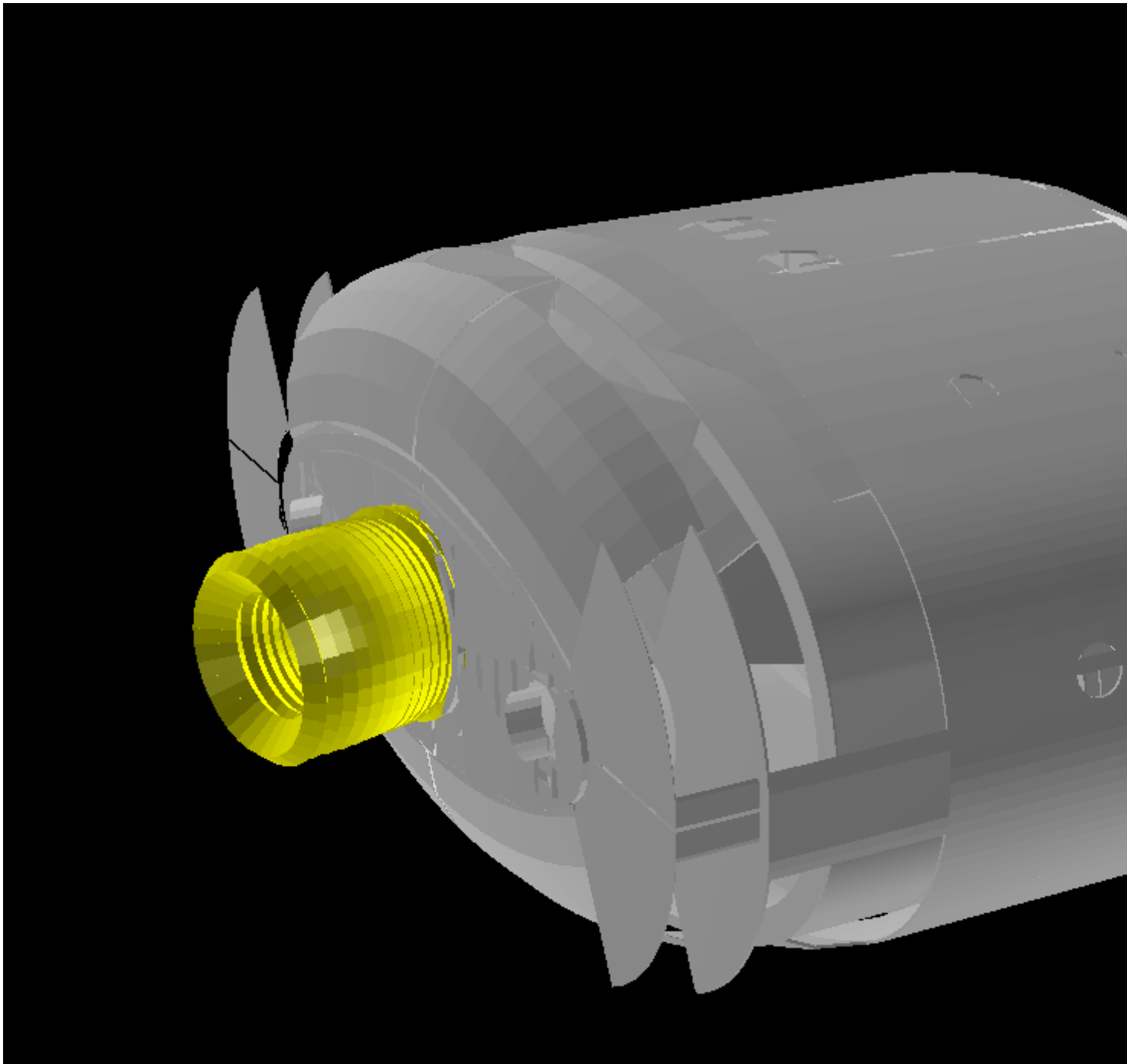

Subject: Re: CALIFA-SiTracker-GLAD geometry conflict
Posted by [Hector Alvarez Pol](#) on Thu, 09 Mar 2017 18:25:12 GMT
[View Forum Message](#) <> [Reply to Message](#)

Hi Ana,

last time I was testing the CALIFA position, it was correctly located with respect to the nominal target position.

If this is true, the magnet is misplaced by around half a meter in this geometry file.

For a fast check to determine if CALIFA is correctly centered, you could find where the origin is

in your plot or simply visualize a reaction vertex...
the CALIFA barrel should be located as it is in the attached picture (side view).
A displacement of half a meter as it is shown in your pic would mean that the vertex could be located outside the Barrel.

Regards,

File Attachments

1) [1211.jpg](#), downloaded 227 times

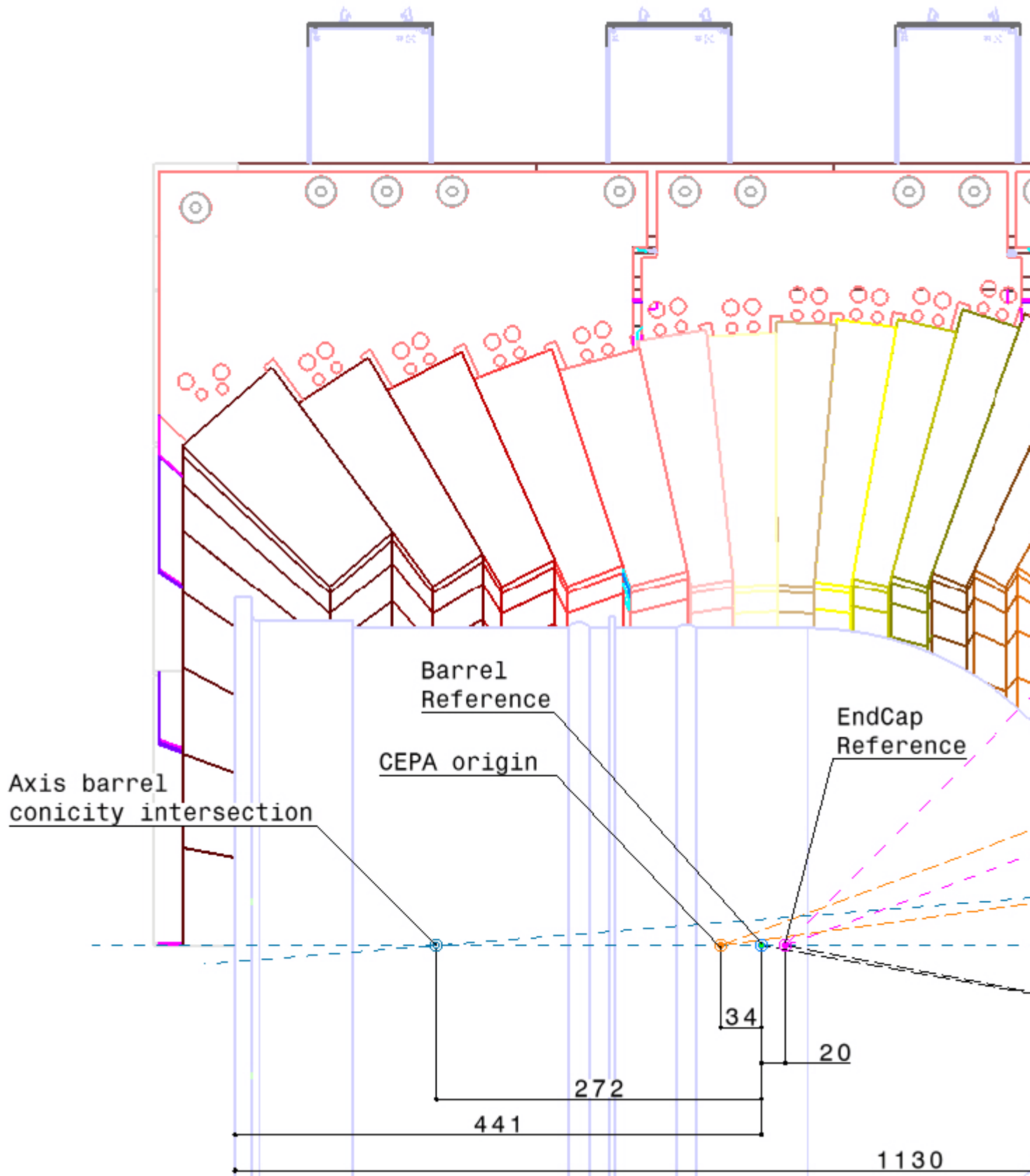

Subject: Re: CALIFA-SiTracker-GLAD geometry conflict
 Posted by [Michael Heil](#) on Mon, 13 Mar 2017 13:41:45 GMT
[View Forum Message](#) <> [Reply to Message](#)

Hello Anna,

here is my view of how to solve this problem: We used to have the target Position at $x=0$, $y=0$ and $z=0$ per Definition. The distance from the target position to the entrance flange of GLAD is 1062 mm. And Califa has also a nominal position relative to the target. If both are at this position there should be now overlap anymore.

Subject: Re: CALIFA-SiTracker-GLAD geometry conflict
Posted by [Anna Corsi](#) on Tue, 14 Mar 2017 21:31:21 GMT
[View Forum Message](#) <> [Reply to Message](#)

Dear Hector and Michael,

Thank you for your replies.

In my understanding (see attachment) the GLAD position is such that the entrance flange is rather ~50 cm from the origin (target center), so it should be shifted downstream.

For information, the create_glad_geo file I used originally has DistanceToTarget = 350 (cm).

Best regards,
Anna

File Attachments

1)
downloaded 339 times

