

---

Subject: New Muon Geometry

Posted by [StefanoSpataro](#) on Fri, 24 Jul 2009 09:09:07 GMT

[View Forum Message](#) <> [Reply to Message](#)

---

Hello,

I have committed in svn the last version of the muon detector geometry (done by George), including also the muon filter.

Inside the code there are also the classes to create the return yoke and the absorber, considering that the actual version of the solenoid is not working.

The following is the plot of the geometry:

You can see the hole for the target pipe, and the additional muon filter. DCH geometry should be tested, to see if it fits inside the muon filter (the size is taken from integration design ver. 0.1.15 (2009-06-05)).

In macro/mdt you can find the sim\_muon.C macro to use that geometry (waiting that the solenoid is ready).

Regards

#### File Attachments

---

1) [newmuon.gif](#), downloaded 669 times

Name

GLViewer::TGLSAViewer

Clip Type

- None
- Plane
- Box

Clip away inside

Edit In Viewer

Show In Viewer

aX +

bY +

cZ +

d = 0

Apply

Reset

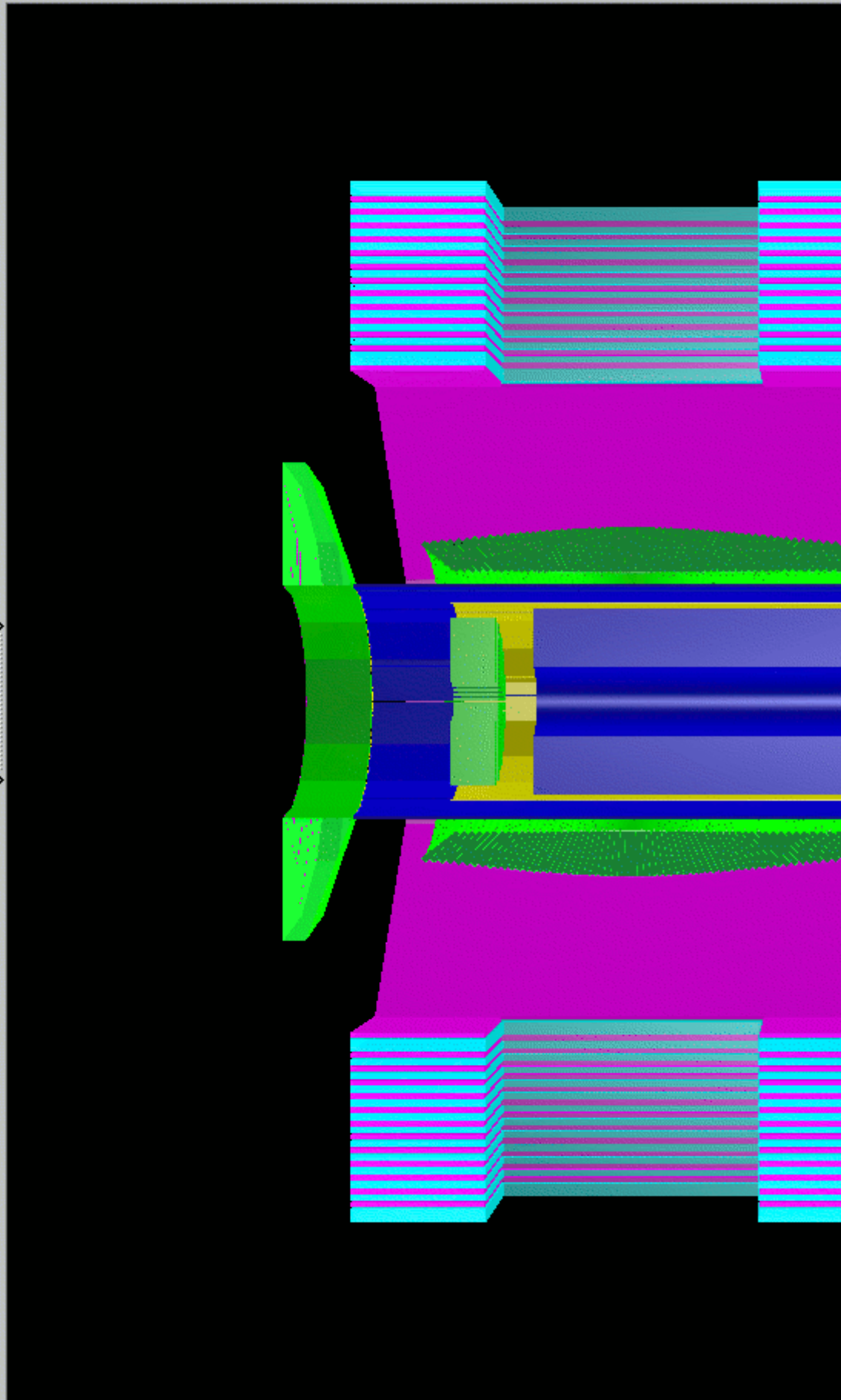

Subject: Re: New Muon Geometry  
Posted by [Valery Rodionov](#) on Fri, 09 Oct 2009 06:12:56 GMT  
[View Forum Message](#) <> [Reply to Message](#)

---

Hi

Nice view of muon detector geometry, but  
the real muon system geometry is different and more complicated.

Valery

---

Subject: Re: New Muon Geometry  
Posted by [Johan Messchendorp](#) on Fri, 09 Oct 2009 07:46:32 GMT  
[View Forum Message](#) <> [Reply to Message](#)

---

Dear Valery,

....then the question will be "How the real muon geometry should look like"?!?

Greetings,

Johan.

---

Subject: Re: New Muon Geometry  
Posted by [Stefano Spataro](#) on Fri, 09 Oct 2009 07:52:25 GMT  
[View Forum Message](#) <> [Reply to Message](#)

---

The "Torino" design implemented in PandaRoot consists on sensible planes placed at the official positions, for tracking studies (which I am doing) and physics analysis about background rejection.

The "Dubna" design is the same (in general terms) but has a high level of details (box/tube/wire). At the moment there are no "ProcessHits" or other functions for simulation inside PandaRoot and digitization, only geometry root file.

---

Subject: Re: New Muon Geometry  
Posted by [Valery Rodionov](#) on Fri, 09 Oct 2009 08:10:05 GMT  
[View Forum Message](#) <> [Reply to Message](#)

---

Hi Johan

at the end of July 2009 A.Efremov put an revised magnet version on PANDA Wiki -> Magnet -> Internal. Our model are in according to this final (I hope) magnet version. In pandaroot we have an oldest magnet version (PandaSolenoidV833.root). So we are waiting for the new magnet revision.

---

The muon system files are:

muon\_FS.root -> Forward System (MDT + Fe)

muon\_TS\_barrel.root -> Yoke: barrel part

muon\_TS\_endcap.root -> Yoke: endcap part

Up to now there is no geometry file for Muon Filter. We are waiting for drawing from DC side hole in plate).

---

---

Subject: Re: New Muon Geometry

Posted by [Stefano Spataro](#) on Fri, 09 Oct 2009 08:13:07 GMT

[View Forum Message](#) <> [Reply to Message](#)

---

Valery Rodionov wrote on Fri, 09 October 2009 10:10pandaroot we have an oldest magnet version (PandaSolenoidV833.root). So we are waiting for the new magnet revision.

For this reason, in the Torino design, the magnet version we are using is constructed inside the MDT classes, so that one can have the correct amount of iron without using the old-fashioned solenoid.

Still the coils are missing within this design, I hope Tobias can convert just them, in order to have almost everything running.

---